

Timber-frame restoration

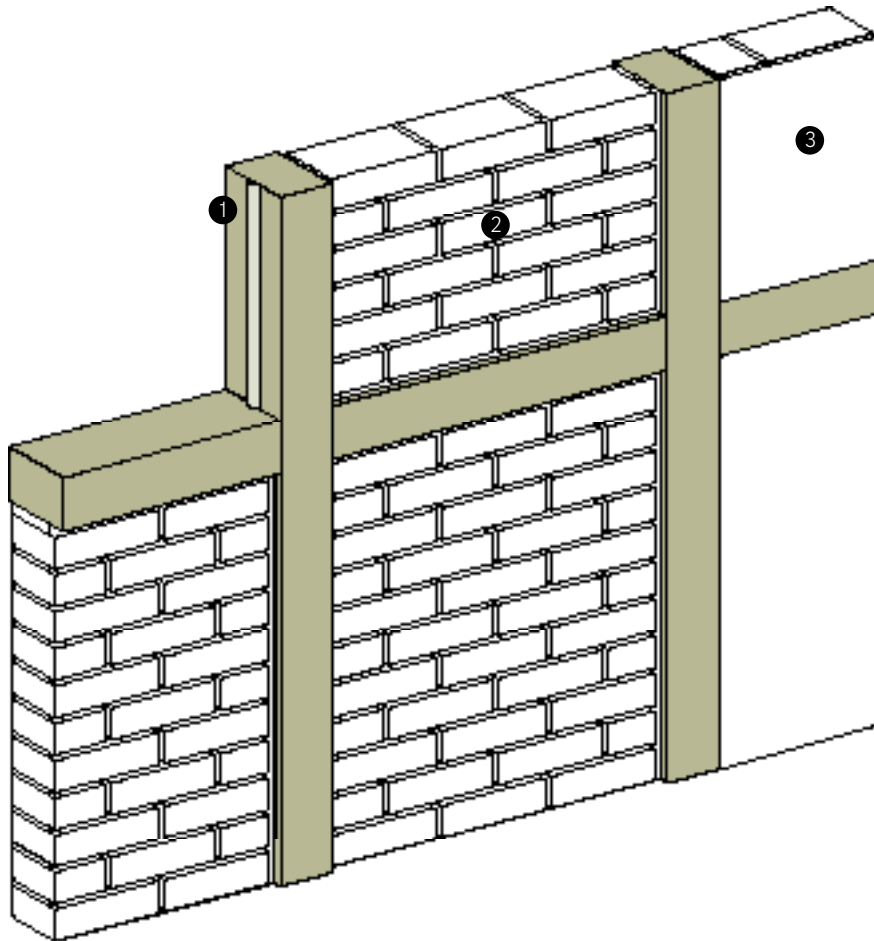

Clay block masonry and exterior plaster
Timber frame filling repairs and exterior plaster
Slatted timber ceilings

Clay block masonry and exterior plaster



	Wall structure	Dimensions	CLAYTEC Products
①	Chamfer strips	H= 1.2 cm	00.050
②	Light clay blocks	Thickness = 11.5 cm	07.011, .012
③	Exterior plaster and coating	Thickness = 1.5 cm	21.200, .350, .525

CLAYTEC clay blocks and light clay blocks are modern building products with the properties of historic clay building materials. Clay block masonry is a low-cost alternative compared to labour-intensive historical infill techniques.

The half-timbered houses of central Europe were built of wood and locally available infill materials, usually clay. A common feature of all these building materials is that they are natural raw materials that can be used directly for building purposes. The skilful use of traditional materials led to the emergence of a building culture whose key elements are the compatibility and coherence of the building materials. Numerous owners of half-timbered houses have once again come to appreciate their harmonious appearance and aesthetics and base their decision for clay building materials on this aspect.

What's more, thanks to its low moisture content and high capillary action, clay preserves exterior wooden beams that are exposed to the weather.

Clay block masonry and exterior plaster

This description focuses on timber frame infill. Infills for interior walls are generally less challenging and are carried out correspondingly. Please refer to the CLAYTEC "Interior insulation worksheet" for interior thermal insulation options and the CLAYTEC "Clay plasters worksheet" for interior clay plasters.

According to DIN 18945, earth or clay blocks are categorised according to their areas of application and with regard to the effects of moisture in application classes (ACs). The highest class (AC Ia) is required for plastered exterior masonry exposed to the weather on visible half-timbered walls. But this is only allowed in (driving rain) stress group I according to DIN 4108-3 and/or after careful examination of the local driving rain exposure.

One excellent product for infill is the light clay block 1200 NF (CLAYTEC 07.011), as are the light clay blocks 800 NF (CLAYTEC 07.012) and 900 2DF (CLAYTEC 07.004)*. The light clay block 900 3DF (CLAYTEC 07.015)* is suitable for timber frames with very broad beams. When choosing the blocks, remember that lightweight bricks help improve the thermal insulation whereas heavier bricks offer better properties with regard to moisture protection. The material needs are approx. 50 NF bricks or 33 2DF bricks and 3 DF per m² of timber frame area. 25-30% of the overall surface area of half-timbered walls can be subtracted for the timber share. When calculating quantities for all types of clay blocks, 3-4% breakages must be allowed for.

Lightweight clay masonry mortar (CLAYTEC 05.022 and 10.122) is used to lay the bricks, as regulated in DIN 18946. The mortar needs are around 27l per m² for NF masonry and around 20 l per m² for 2DF masonry. A 1.0-t Big Bag (earth moist) produces 700 l of finished masonry mortar, a 25 kg bag (dry) produces 20 l. Clay masonry mortars are regulated in DIN 18946. In addition, 2.5 m of triangular battens (CLAYTEC 00.050) are needed for each m² of timber frame surface area.

We recommend the use of stainless steel mesh plaster lath (CLAYTEC 35.100, screws 35.110) for half-timbered walls that are exposed to above-average weathering. We can offer gräfix breathable lime mortar for the exterior plaster. The final coat is gräfix 680 lime paint (CLAYTEC 21.525).

Nogging the infill sections

Before starting any repair work, make sure that all woodwork and any interventions in the static structure have been completed.

Begin by nailing triangular battens to the lateral beam surfaces in the infill sections (approx. 8 cm gap to the front edge). These battens form an upstand that stabilises the infill with the expected transverse shrinkage of the wooden beams. They have little effect on the resistance to wind and driving rain. Making a groove in the external face of the bricks that rest against the timber frame is time-consuming and superfluous. Additional triangular battens can be nailed to the top and bottom of the beams for larger infill sections.

Working with clay blocks and clay mortar is no different to normal masonry work; the principles of proper use of masonry materials also apply here. Clay blocks can be easily chiselled into shape or cut with an aerated block saw. Clay mortar does not harden as the result of a water-based chemical curing process ("setting") but through drying, which means the bricks do not have to be wetted in the same way as when using lime mortar. The vertical and horizontal joints should be no larger than 1-1.5 cm. Pay particular attention to flush-jointed laying of clay block masonry so as to avoid cavities and thus reduce settlements in height to a minimum.

The masonry joints are levelled off. Scrape out any masonry mortar that has not yet set to create a sharp-edged recess of max. 3 mm in order to improve the later plaster adhesion.

Application classes of clay blocks

Choice of clay blocks

	NF	2DF/3DF
Number of bricks	50	33
Mortar requirement (litres)	27	20

Block & mortar needs per m² depending on the block format

Clay masonry mortar

Exterior lime rendering

Triangular battens

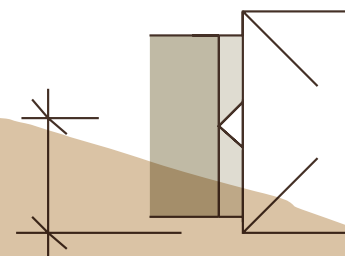

approx. 8 cm between the beam's outer edge and the middle of the triangular batten

* DIN tests are performed for 07.004 and 07.015, obtain separate data if necessary.

The surface should be protected against heavy driving rain, but above all against water splashes (e.g. from the scaffolding flooring), until it is plastered.

Execution of the lime plaster

The masonry must be absolutely dry before the lime plastering work starts. Intermediate courses of clay undercoat plaster are not permissible; apply the lime mortar directly to the masonry. Brush off the masonry with a dry brush to remove any loose sand and dirt. Wet masonry carefully before applying the first layer of plaster. Clay blocks have a very high water-absorptive capacity, the lime plaster must not be deprived of the water needed for the setting process. Check with every new infill section that there is enough moisture in the substrate. However, the substrate must not be saturated with water; the clay should display only a uniform dark colour. Water accumulation in the pores near the surface would block the bond between the lime plaster and substrate. On account of the share of coarse grain and the animal hairs it contains, gräfix 61 coarse lime basecoat render with hair (CLAYTEC 21.200) is an ideal breathable lime mortar for manual plastering of historic clay timber frame fillings.

Wet the substrate!

suitable lime mortar

The plaster is always applied in several layers. If the lime plaster is applied to the clay block masonry without a mesh plaster lath, the overall plaster thickness must not exceed 1.5 cm. Thicker plasters are not appropriate. The following plaster structures are possible depending on the desired surface texture:

Plaster structure

The thickness of the coarse lime basecoat render with hair must not be less than 8 mm or more than 12 mm for each layer. (Recesses > 3 mm are regarded as the plaster base when determining the plaster thickness). Two layers of coarse lime basecoat render with hair should be used

Rough surface (rustic)	Fine surface	Very fine surface
61 coarse lime basecoat render with hair	61 coarse lime basecoat render with hair	61 coarse lime basecoat render with hair
61 lime basecoat render	61 fine lime thin-coat render	61 fine lime thin-coat render
		66k lime render smooth

as undercoat plaster for thick layers and on very large infill sections > 2.5 m² to minimise shrinkage and sag cracks. See below for details of the surface and drying of the first layer (analogous).

The first layer of the lime basecoat render with hair is levelled off with a wooden board (15 x 40 cm). The mortar is pressed against the substrate and worked in in zig-zag movements. The joint recesses must be completely filled and grouted. The grain is set up by working in with the wooden board. This large, open surface provides the ideal basis for setting. It means the plaster surface is so rough it does not have to be combed. Metal smoothing tools are unsuitable for layers of basecoat plaster because they leave a compacted surface that is almost impossible to roughen up correctly. Alternatively, the mortar can be applied with a large triangular bricklayer's trowel.

Apply the 1st coat of plaster

Leave the coarse lime basecoat render with hair to dry fully (at least one day/mm of basecoat plaster). Cracks may appear. Final fine top coats can be applied with CLAYTEC Japanese trowels or metal smoothing tools (see CLAYTEC product sheets 21.350 or 21.400). The top coats are rubbed up or otherwise moulded depending on the temperature, plaster thickness and absorptive capacity of the substrate. When applying and smoothing the plaster, work from the edge of the infill section towards its centre and not vice versa. The bond is particularly vulnerable at the edge area. The mortar here must be pressed in at the start of the movement wherever possible. We recommend a cut of around 2-3 mm in depth with the trowel at the beam connection. The beam connection should not be executed as a bevel.

Apply the top coat of plaster

Clay block masonry and exterior plaster

If temperatures are too low and the moisture too high, the plaster only sets very slowly and insufficiently. In hot or windy weather, on the other hand, the plaster has to be kept moist in the first few days, e.g. with a garden sprinkler (fine mist) to stop it drying out too fast.

Windows, surfaces of oak or other visible timber components must be covered carefully during the lime plaster work; lime splashes must be removed from the visible surfaces of the beams immediately.

Protect visible wood areas

The plaster should be given a vapour-permeable coating with low film-forming characteristics before the first frost to produce a uniform colour and guarantee adequate protection against the weather. Gräfix 680 lime paint is ideal for this. This is applied in the fresco technique with a brush to the still moist plaster. Plaster and paint then set together. Dry plaster must be pre-wet 1-2 days before work (full mist), and then pre-wet again immediately before every coating (mist). We recommend a silicate facade paint for half-timbered facades exposed to heavy weathering.

Coating

Use of mesh plaster laths

The bond (see above) between the clay substrate and lime plaster produced by traditional means is sufficient for a timber-frame wall exposed to normal weathering. In other cases, it is advisable to protect the timber-frame wall with shuttering or flat plastering. However, if areas are to be executed as visible timber frames that are exposed to heavy stress, e.g. through weathering, sunlight, timber deformations or vibrations, the use of a mesh plaster lath contributes to their durability. The CLAYTEC stainless steel wire mesh absorbs the loads from the plaster shell and holds the plaster to the substrate. It also has a reinforcing effect in the tension zone if swelling wooden beams press against the sides of the lime plaster layer and threaten to push it out. Even coarse-grained mortar can also pass through the 17 mm wide mesh quite easily. The mesh is fastened in the infill section in the offsets with 15-20 stainless steel facade screws for each m². Fastening to the timberwork is not advisable because even the slightest of deformations in the wood can lead to damage. A good and extensive bond has to be created between the lime and clay irrespective of the lath: before installing the lath, the plaster base has to be prepared just as carefully as when working without a mesh.

Purpose of the lath

Fixing

Areas still need to be well prepared!

Alternatively, embedding a reinforcing mesh suitable for outdoor is another way of helping secure the plaster in place to a limited extent. This is worked into the first layer of plaster and, again, is not fastened to the beams.

Reinforcing mesh

Further information on exterior plaster on clay infills

Timber-frame restorations often entail major interventions in the structure, changes of use, additional loads, altered interior temperatures, etc. The timber-frame areas should be plastered as late as possible, irrespective of their infill material. Movements of the entire supporting structure and rotary, swelling or shrinkage movements of the beam (often in the old or "seasoned" beams too) occur more frequently in the first months after a repair. The exterior plaster should ideally be applied only when the building is in use and one heating period has passed. The clay infill can be exposed to weathering for a period of time with no problems; protective measures should be taken on the weather sides if necessary.

Time of plastering

Clay plaster is usually unsuitable for the outer finishing plaster because it is a water-soluble material. However, a surprising and often absolutely adequate resistance to moisture can be achieved by adding traditional additives and through suitable coatings. Nevertheless, the preparation and final treatment of these kinds of clay exterior plasters requires great experience. An undercoat plaster of clay mortar is not recommended as a lath for lime plaster:

Clay plaster as exterior finishing plaster

Clay block masonry and exterior plaster

clay blocks are a better lath than a clay undercoat plaster; this is only permissible in connection with certain repairs (see page 7 onwards).

no intermediate layers of clay undercoat plaster!

A lath and reinforcing mesh offer the greatest safety for plaster. However, the stress placed on the area by weathering etc. poses a problem not only for the durability of the exterior plaster but also for the future of the entire timber-frame wall. If the stress is so high that the plaster adhesion appears doubtful, despite careful mechanical preparation of the clay areas (see above) and laths have to be used, you should consider an alternative to a visible timber frame design so as to protect the overall structure. In the past, when the picturesque appearance of the timber frames was considered immaterial, areas exposed to excessively high stress were always given protection against the weather.

Visible timber frames or protection against the weather

The creation of wide bevels between the exterior plaster and the beams, as sometimes required, has a mixed impact: if the timber-frame beams have enough room for swelling and shrinkage movements in the broad gap, they exert a lower lateral pressure on the plaster surfaces and thus a lower stress on the bond between clay and lime plaster. Furthermore, edges broken by chamfering have a more favourable geometry and are less at risk than 90° angles. However, this kind of joint acts like a funnel, particularly with wind on the driving rain side, that collects the water from the surface of the timber frame surface area and lead it into the building component. Summing up, lime plaster should only be offset by around 1 mm at the edge to the wooden beam. A circumferential trowel or cutter incision to separate the wood and plaster is an absolute necessity, though this only needs to be 2 mm deep.

Bevel?

Trowel incision?

Attempts to seal the joints with permanently elastic compounds have not been successful in the past: Rainwater continues to penetrate the building component despite every effort, but this is "safely" prevented from drying out. The best protection is a good craftsmanship in making the connection joints.

"Permanently elastic" seal

Drying-out of different infill masonry (indicative test)

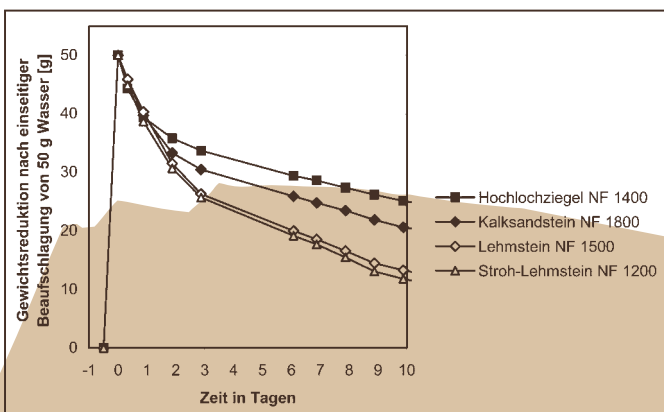

Timber frame filling repairs and exterior plaster

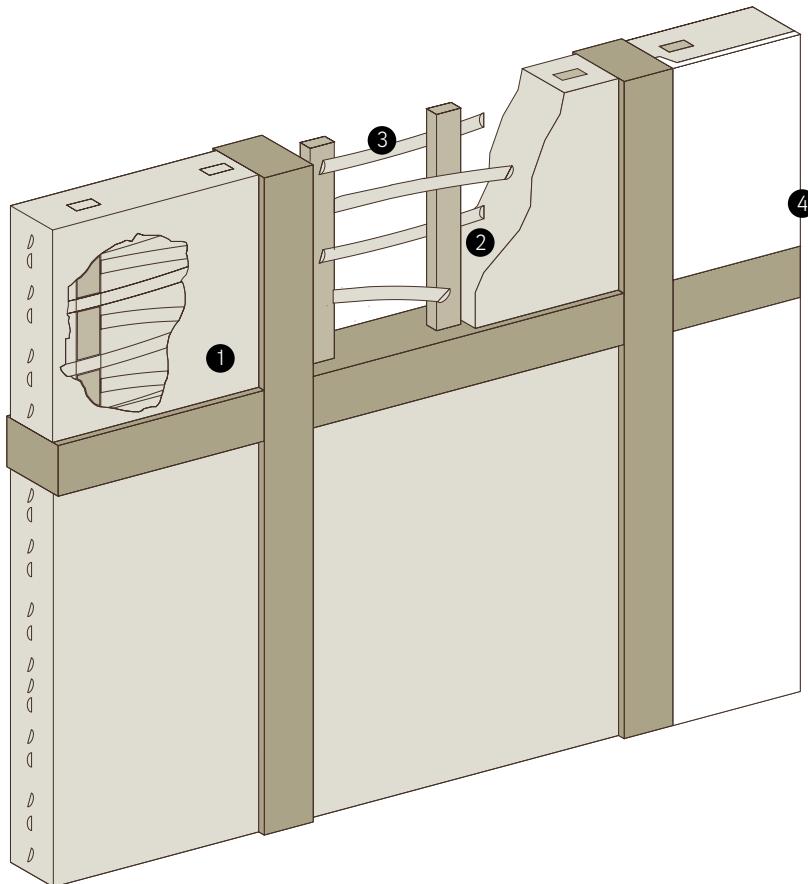

	Wall structure	Dimensions	CLAYTEC Products
1	Straw clay	--	04.004 and 04.005
2	Oak stakes	26 x 60 mm	30.001 and 30.002
3	Willow rods	Thickness = approx. 2.5 cm	31.001
4	Exterior plaster	Thickness = 0.3-1.5 cm	21.200, .350, .525

Old timber-frame infills of clay may be damaged by the effects of time and weather and have to be repaired. The choice of exterior plaster system is closely related to the choice of techniques used for this repair.

Half-timbered houses used to be infilled with clay: building clay was readily available and it was easy to learn clay building techniques. This led to numerous regional differences and in some cases very advanced methods to fill the spaces between the posts and beams.

One popular method was to clamp stakes in previously mortised grooves, weave softwood stakes in the gaps and then fill these with straw clay. In other regions, the strands of straw clay were wound around the stakes and placed in the timber frame as close-fitting lattices.

The timber framework and infill form an inseparable material whole. The prevailing opinion now is to preserve these as an ensemble wherever possible.

Clay preserves the wooden beams on account of its low moisture content and high capillary action. Clay infills are easy to repair. The binding capacity of the clay building materials can be reactivated by adding water; the bond between the old and new clay is easy to restore.

The replacement of clay infills with masonry that has been thoughtlessly practised over recent decades was often the result of a lack of understanding and ignorance of the old constructions. The strength of the infills of stakes and braiding is based on a simple bonding principle: sharpened pieces of wood were clamped in dedicated grooves in the beams, the gaps filled with plaited staves or filled directly with straw clay. This kind of infill can move within the timberwork on account of beam shrinkages or building settlement. This was generally seen as a shortcoming. Straw clay is an unusually soft building material by today's standards. But the modern desire for the highest possible strength is not only out of place for a half-timbered house, unfortunately it is also often damaging.

What's more, the demolition of the inherited clay structure is uneconomical and a destruction of the original and its documentary value.

This description focuses on timber frame infill. Repairs to interior infills are generally less challenging and are carried out correspondingly. Please refer to the CLAYTEC "Interior insulation worksheet" for interior thermal insulation options and the CLAYTEC "Clay plasters worksheet" for interior clay plasters.

Building materials

Building materials for timber frame filling repairs are oak stakes (CLAYTEC 30.001) and willow rods (CLAYTEC 31.001). Stakes (CLAYTEC 30.002) that are chamfered with a polygonal cross-section are very easy to braid and wrap. A bundle of willow rods is sufficient to repair approx. 3-4 m² of a timber-frame wall.

The most important building material for timber frame filling repairs is straw clay, supplied as an earth-moistened raw mass (CLAYTEC 04.004). Straw clay Antik (CLAYTEC 04.005) contains straw that is particularly long and is a very authentic product for repair of listed buildings. A Big Bag of raw mass provides 0.7 m³ of finished straw clay. Smaller repairs are carried out with clay undercoat plaster (CLAYTEC 05.001, 05.002 or 10.010).

Clay timber struts are made with building clay (CLAYTEC 01.003, milled 01.002 and 10.001) and straw; see also worksheet 2.2.

We can offer various breathable lime mortars for the exterior plaster. We recommend the use of stainless steel mesh plaster lath (CLAYTEC 35.100, screws 35.110) for half-timbered walls that are exposed to above-average weathering. The final coat is gräfix 680 lime paint (CLAYTEC 21.525).

Initial situation and preparation

Before starting any repair work, make sure that all woodwork and any interventions in the static structure have been completed. If you still expect some movements, you should wait a while before starting the repair and exterior plaster.

Timber-frame construction

Begin by carefully removing the remains of the old exterior plaster. Its condition, layer thickness and plastering method often provide valuable tips on the further treatment of the outer shell. Incorrect timber frame filling repairs (cement plaster fillings etc.) and loose clay areas that can no longer be kept in place must be removed.

Old topcoats

Repairs to stakes and wattles

Damaged stakes and wattles should be replaced. Unfortunately, this replacement is often only possible at the cost of major damage to the timber frame. Stakes can frequently be stabilised by simply fixing them in place with a few wood screws. Stakes and wattle used to be the supporting structure for the straw clay during the construction of the timber frames; when dry and firm, they form a stable structure together with the inner plaster layers.

Choice of repair method and of exterior plaster system

Areas that are exposed to normal or heavy weathering should receive an extensive straw clay coating and a second layer of lime plaster. If the clay timber frame fillings are seriously damaged and have to be removed down to the wattle, there is usually enough room to make this structure flush with the beams. If the clay timber frame fillings are largely intact on the surface and if the recess between the front edge of the beam and surface of the clay is only a few millimetres, a slight protrusion from the beam is also possible.

Another method is the application of lime-sand slurries and thin fine lime plaster. This is used for largely intact infill sections with a small recess. Caution: this method is normally used indoors and should only be used for areas protected from the weather! However, if the findings show that this kind of plastering on a particular area has apparently proven its worth over a long period, the most advisable practice would be to re-execute according to this method.

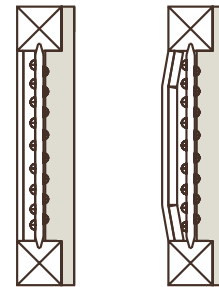

*Two-layer lime plaster:
flush with beams and "cushion-like"*

Flat straw clay overlay and 2 layers of lime plaster

Sweep out the timber frame with a brush and moisten before starting the repair. This removes the clay dust or binds it to the surface. Begin by filling large holes and defects with straw clay (CLAYTEC 04.004). The clay is then applied with a trowel to the entire surface in 2-3 cm thick layer. Straw clay is very "rich": the material may have to be made leaner on substrates of lean or sandy infill clay. A work sample should always be prepared to check the bond between the old and new clay.

The recess between the straw clay and the surface of the beam should be precisely 1.5 cm.

The freshly applied straw clay must be carefully roughened to ensure there can later be a good mechanical bond with the lime plaster. Pay great attention to ensuring a good adhesive bond between the layers. There are many different ways to roughen the surface; the best has proven to be perforating the surface with a fine plaster scraper. This pricks holes into the freshly applied straw clay. The straw fibres that protrude from the surface are also important for the bond between the clay and the lime; they form the most stable bridges between the layers.

The surface should be protected against heavy driving rain, but above all against splashes (e.g. from the scaffolding flooring), during the drying period.

The clay substrate must be absolutely dry before starting the plastering work. Wet the clay carefully before applying the first layer of plaster (spray mist). Straw clay has a very high water-absorptive capacity, the lime plaster must not be deprived of the water needed for the setting process. Check with every new infill section that there is enough moisture in the substrate.

Straw clay application

Thin out?

Recess size

Roughen up

Protection during drying

Wet the substrate

However, the substrate must not be saturated with water; the clay should display only a uniform dark colour. Water accumulation in the pores near the surface would block the bond between the lime plaster and substrate.

On account of the share of coarse grain and the animal hairs it contains, gräfix 61 coarse lime basecoat render with hair (CLAYTEC 21.200) is an ideal breathable lime mortar for manual plastering of historic clay timber frame fillings. *suitable lime mortar*

Please refer to page 4 for the **execution of the lime plaster**. *Coating*

Execution of lime plaster slurries and thin fine lime plaster

Minor defects can be repaired with clay undercoat plaster (CLAYTEC 05.001, 05.002 or 10.010) after wetting the timber frame surface area. This method also requires roughening the surface but remember that the thin plaster topcoat only allows very small projections and recesses. Here too, the straw fibres that protrude from the surface ensure the best bond. *Repairing defects*

A slurry of white lime hydrate and fine sand is worked into the pre-wetted clay plaster as preparatory work.

Lime thin-coat render (CLAYTEC 21.350) is applied with CLAYTEC Japanese trowels or metal smoothing tools. The application thickness according to historic examples is 2-3 mm, or 3-5 mm in the thickest examples. See above for protection of visible wooden parts and for coatings that equalise and protect. *Plaster application*

Please refer to page 5 onwards for tips on **use of mesh plaster laths** and **further information on exterior plaster on clay infills**.

Slatted timber ceilings

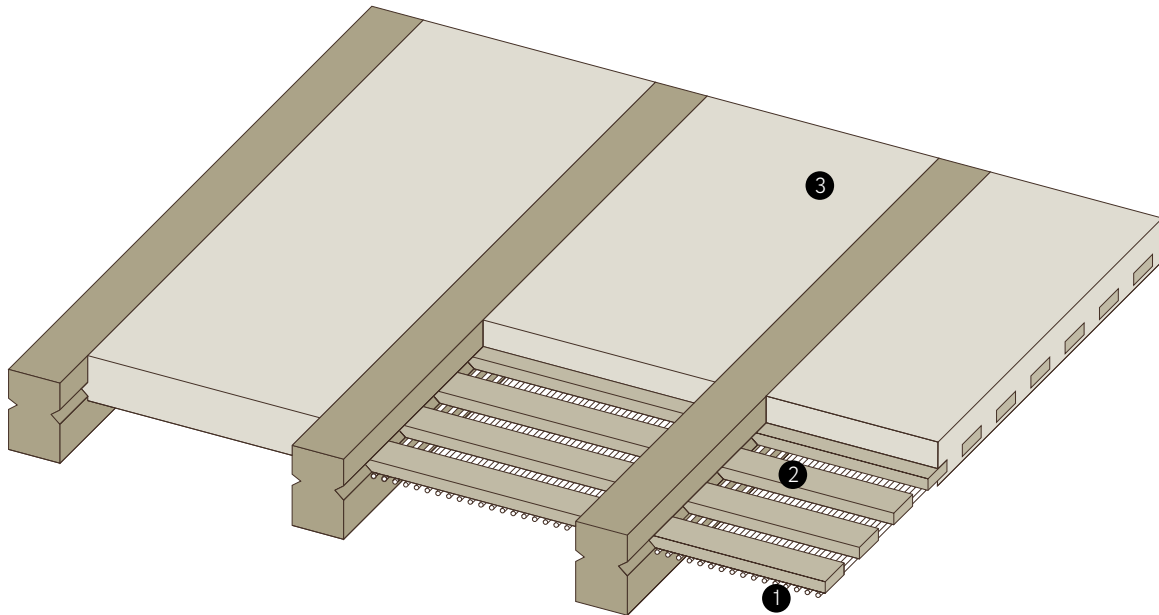

	Ceiling design	Dimensions	CLAYTEC Products
1	Reed matting St 70	--	34.001
2	Oak stakes	26 x 60 mm	30.001
3	Straw clay	Thickness approx. 5-12 cm	04.005

Pointed stakes are clamped between ceiling beams, held in place in a groove, and form the supporting structure for a layer of straw clay applied on top.

This kind of ceiling infill can be found in historic buildings. The simple and logical framing construction determined the design and architectural manifestation of the ceiling. Depending on the position of the stakes in the beam cross-section, either smooth or profiled ceilings could be produced. The beams remained visible or were plastered over together with the ceiling panels.

The straw clay fillings primarily served to fill the cavities, but they also had a soundproofing and fire-retardant effect. Slatted timber ceilings can also be filled with pourable dry earth fill materials instead of malleable straw clay. The design of the ceilings and joists is very important for the appearance and proportions of a room; the variety of forms, many of which have typical regional features, are a valuable cultural heritage.

Building materials: The stakes are sawn oak stakes (CLAYTEC 30.001) with a cross-section of 26 x 60 mm. Around 10 to 12 stakes are needed per m of space between the beams. Include enough reserve in your calculation on account of the offcuts.

Slatted timber ceilings

The reed matting St 70 (CLAYTEC 34.001) is used as lost formwork and a lath on the underside.

The ceiling is filled with straw clay, supplied as earth-moistened raw mass (CLAYTEC 04.004, 1600 kg/m³ solid mortar gross density). A Big Bag of raw mass provides 700 l of finished straw clay. Measure over the wooden parts (beams) when determining the required amounts. You should include enough reserve in your calculation here too.

Building clay (CLAYTEC 01.003, 1300 kg/m³), clay masonry mortar (CLAYTEC 05.020, 1600 kg/m³) or pumice-dry earth filling (CLAYTEC 03.052, 1000 kg/m³) are some of the fill materials available. If the fill materials are to be compacted, add approx. 15-20% when determining the amounts. Dry earth fill material, light (CLAYTEC 03.070, approx. 275 kg/m³) has a particularly low weight.

Clay timber struts are made with building clay (CLAYTEC 01.003, milled 01.002 und 10.001) and straw.

You must consult a structural engineer, especially if the straw clay layer is being used in an old building for the first time or in a thicker layer. If the permissible imposed load and the possible package thickness are specified, the acceptable gross density of the fill material can be determined as a variable. The gross densities depend largely on the degree of compaction; the information above applies for approx. 15-20%. More precise specifications may have to be made and tested on work samples.

Structural design?

Constructing slatted timber ceilings

Before getting started, make sure that all work on the woodwork has been completed. You first have to decide the cross-sectional height at which the stakes should lie; the decision is usually taken based on existing grooves in ceiling parts. The grooves should be approx. 1.5 cm wide and 2.0 cm deep and have a conical, tapering cross-section. Grooves can be milled or cut into the beams by a carpenter before installation. The grooves can be produced on site with an axe, chisel or chain saw.

Position of the groove

Grooves

The old grooves in the beams can often be used, though they may have to be widened or deepened.

The stakes are made from sawn oak. Riven wood, such as is used for roof shingles that are exposed directly to running water, is not necessarily more resistant to the stress of contact moisture (installation moisture level of straw clay). Experience has shown that "green" oak is less at risk from the installation moisture level of the clay than centuries-old dry wood. The stakes should not be longer than 0.75 m. They are roughly cleaned of sapwood and residual bark and their ends sharpened on four sides with an axe or saw. The clearance between the stakes is 2.5-4.0 cm. The stakes are clamped firmly between the beams, but must not push them apart. A careful execution ensures stability during any possible transverse shrinkage of the ceiling beams. The longitudinal shrinkage of the stakes is negligible in this context.

Stakes

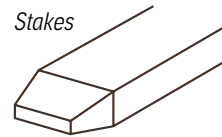

Stake sharpened on four sides



Coating with reed matting



Stapling the reed matting to the base wire

Slatted timber ceilings

The straw clay is installed in the ceiling in a soft malleable consistency and usually lies flush with the upper edge of the ceiling beams. It has to enter all of the cavities and spaces between the stakes and is compacted and smoothed off roughly like screed using trowels or other tools.

Installing the straw clay

One special variant is infilling with clay timber struts (in some regions also called "cobs"). In this method, strands of straw and clay are wound around stakes laid out on a table and these are then clamped in a groove, as explained above. The straw is initially dipped into a thick slurry of clay. The material can then be stored for a few hours or even days ("aged") to make it easier to work with. Bundles of the clay-embedded straw are then wound around the stakes (which have been cut to size beforehand and/or "dry-fit" into the ceiling to make sure they fit). The finished clay timber struts, whose diameter depends on the findings (often 10-15 cm), are now pushed into the ceiling on top of each other. Any uneven spots are levelled out with clay undercoat plaster (CLAYTEC 05.001, 05.002 or 10.010).

Ceilings with clay timber struts



Clay timber struts

Subsequent processing and plastering

The drying time for the slatted timber ceiling with straw clay has to be taken into account when planning the building period; one general rule of thumb is to allow approx. 4 to 6 weeks for a filling height of 5-8 cm. You must ensure good ventilation during drying, so that outdoor air can flow over the entire surface of the straw clay. If this cannot be safely and permanently guaranteed with no interruptions, mechanical drying must be used. Drying of the construction should be the responsibility of the executing clay construction company, assuming it has sufficient experience.

Drying

The clay must be protected against contamination and premature mechanical stress.

Mechanical construction drying

Before laying any wooden floor or other coverings, the straw clay and the dry earth fill material must be absolutely dry. If you have any doubts after a visual inspection, the residual moisture can be determined with a simple Darr dryness test at 40 °C. Dry clay building materials have a practical moisture content of 2-3%.

There are various options for plastering the underside of the ceiling. In many historic ceilings, the ceiling panels and beams are plastered over. With visible wooden ceiling beams, only the spaces in between are plastered or covered with a drywall construction such as the clayboard (CLAYTEC 09.004). The ceiling can also be given a smooth underside in a drywall construction and plastered, or even suspended using the clayboard.

Plastering

The topic of ceiling plaster is dealt with in the CLAYTEC "Clay plasters worksheet".

Please note:

the information in the worksheets is based on many years of experience in the execution of clay construction work and the use of our products. No legal obligation can be derived from this. Adequate experience as a craftsman and the necessary skills from the relevant building trades are assumed. The latest version of the worksheet is always valid; this is available from www.claytec.de if necessary. Copying and publication are not permitted, even in extracts. Copyright CLAYTEC e.K.

Material and building component values

Table 4.1.1: Structural values of the CLAYTEC building materials used for slatted timber ceilings

	Item no.	Mean gross density (kg/m ³)	λ (W/mk)	μ -value 04.004
Straw clay	04.004, .005	1600	0.73	5/10
Sawn oak stakes	30.001, 002	800	0.2	-
Clay undercoat plaster	various	1700	0.82	5/10
Stakes, reed matting, straw clay - average*	-	1500	0.66	5/10
Clay timber struts *	-	800	0.25	5/10

* for thickness = approx. 10 cm

λ -values and μ -values for the clay building materials taken from "Lehmbau Regeln" of the Dachverband Lehm e.V. or test certificates (if proof is required with values according to DIN 4108 s. d.)

Table 4.1.2: Weight per unit area of the fillings for slatted timber ceilings in kg/m²

	Slatted timber ceiling	Ceilings with clay timber struts
additional straw clay package 4 cm	110	164
additional straw clay package 6 cm	140	200
additional straw clay package 8 cm	170	230
additional straw clay package 10 cm	200	260

Conditions:

Slatted timber ceiling: Basic construction of stakes and reed matting Thickness = approx. 3.5 cm

Ceiling with clay timber struts: Basic construction of clay timber struts: thickness = approx. 10 cm

Table 4.1.3: Sound reduction index R'_w and footstep sound level L'_{n,w} of slatted timber ceilings in dB based on calculations by SWA-Institute, Aachen (extrapolated from measured values and theoretical assumptions)

	Sound reduction index R' _w	Footstep sound level L' _{n,w}
Slatted timber ceiling, straw clay 8 cm	approx. 45	approx. 72



CLAYTEC GmbH & Co. KG

Nettetaler Straße 113
41751 Viersen-Boisheim

Telephone: +49 (0)2153 918-0
Fax: +49 (0)2153 918-18

Email: service@claytec.com
www.claytec.de/en

Distribution in Austria:
Claytec Lehmbaumstoffe GmbH

Stranach 6
9842 Mörttschach

Telephone: +43 (0)699 172 188 77

Email: info@claytec.at
www.claytec.at